



# TELSCOPE INSTALLATION MANUAL

Version 1.2

TELKO AS

**TABLE OF CONTENTS**

PHYSICAL INSTALLATION ..... 2

    BEFORE YOU BEGIN ..... 2

    MOUNTING..... 2

    POWER..... 3

    NETWORK ..... 3

    COMPORTS ..... 4

    VIDEO..... 4

    USB ..... 5

    BAM ..... 5

    INCLUDED IN BOX..... 5

    VDR ..... 6

SETUP TELSCOPE WITHOUT MONITOR (SERVICE PORT) ..... 7

TECDIS LINK TO TELSCOPE ..... 8

CONFIGURATION ..... 10

    NETWORK SETUP..... 10

    OVERVIEW ..... 12

    DATA COLLECTION SERIAL ..... 12

    DATA MAPPING ..... 13

    VDR - IEC 61162-450 Edition 2.0 2018-05 (OPTION)..... 13

    ADMIN USER..... 14

    INSTALLATION REPORT ..... 14

    START / STOP ..... 15

GENERIC BLOCK DIAGRAM..... 16

**DOCUMENT REVISION HISTORY**

Ver No	Rev Date	Document Information
1.0	2025-03-19	TELSCOPE Installation
1.1	2025-03-22	Minor update, Rearrange Section and Task
1.2	2026-05-16	Minor update



## PHYSICAL INSTALLATION

The following illustration provides an overview of mounting and wiring of TELSCOPE

### BEFORE YOU BEGIN

Check that you have all relevant information about IT Settings for the TELSCOPE installation this will normally be provided by the Integrator or Customer IT Department

- IP Address
- Subnet Mask
- Gateway IP
- Switch, Port Nr
- Check with the responsible Integrator about which instruments that will be connected to TELSCOPE
- Check with the responsible Integrator about which hardware options that will be connected to TELSCOPE

### MOUNTING

The processor unit can be mounted inside a console or other suitable space.  
When selecting a mounting location, keep in mind the following points.

- Select a location where vibrations are down to a minimum
- Locate the unit away from heat sources because of heat that can build up inside the cabinet
- Locate the equipment away from places subject to water splash and rain
- A magnetic compass will be affected if the processor unit is placed too close to the magnetic compass.
- Observe the compass safe distances to prevent deviation of a magnetic compass
- When the best location has been found, mount the TELSCOPE using the included brackets

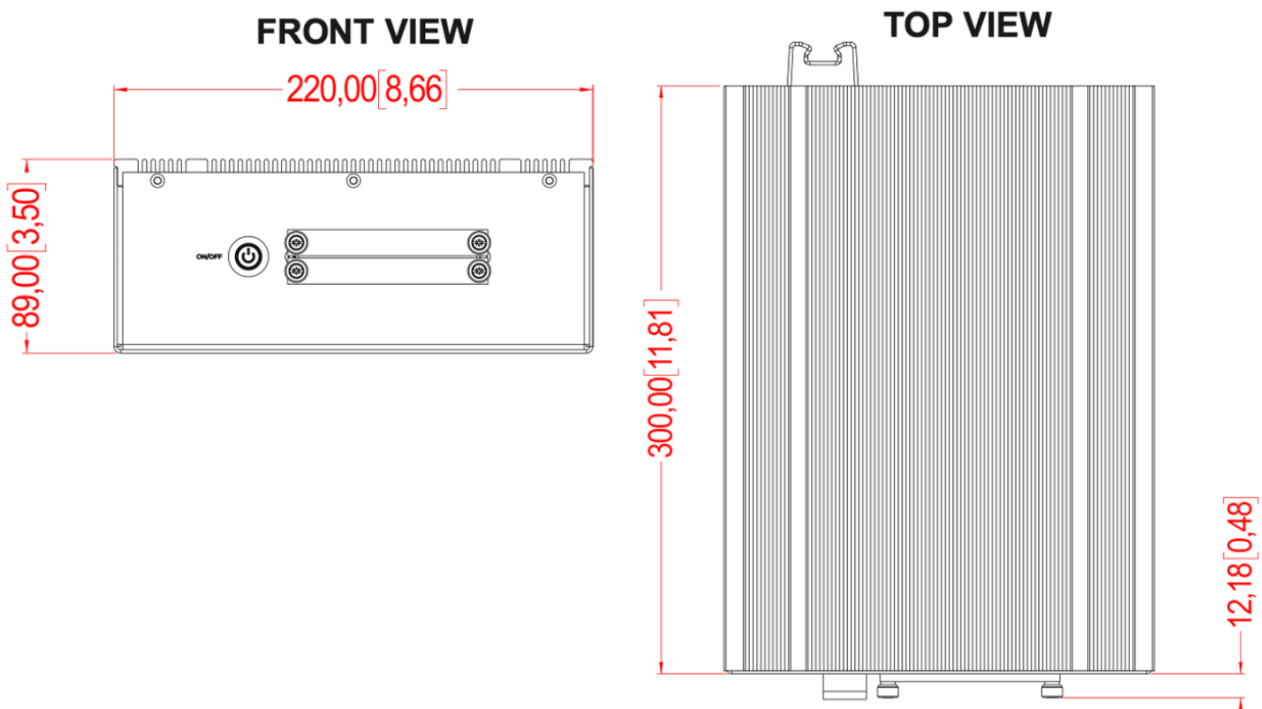

## POWER

TELSCOPE have Multipower, with uninterrupted switchover if power loss occurs 100-240 VAC / 24 VDC (optionally via UPS) TELSCOPE need to be connected to 220 VAC or 24 VDC emergency power  
Power Consumption Max 50W, Normal 39W

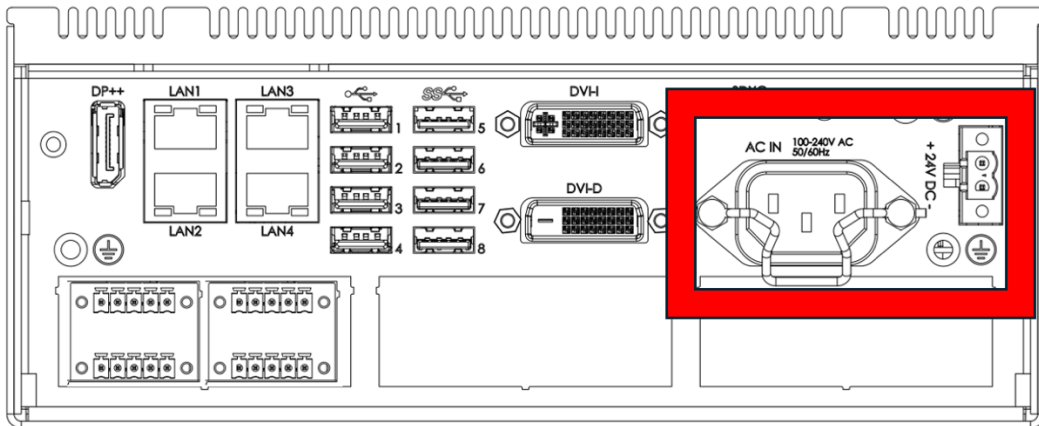

## NETWORK

Ensure that the TELSCOPE network connectors are wired according to their intended purposes

- LAN1 (enp3s0) - Ship Network (**Requirement**)
- LAN2 (enp4s0) - IEC 61162-450 VDR (Option read more section Configuration VDR)
- LAN3 (enp1s0) - Spare / Automation System (Option)
- LAN4 (enp2s0) - Service Port (Read more Section Setup Without Monitor)

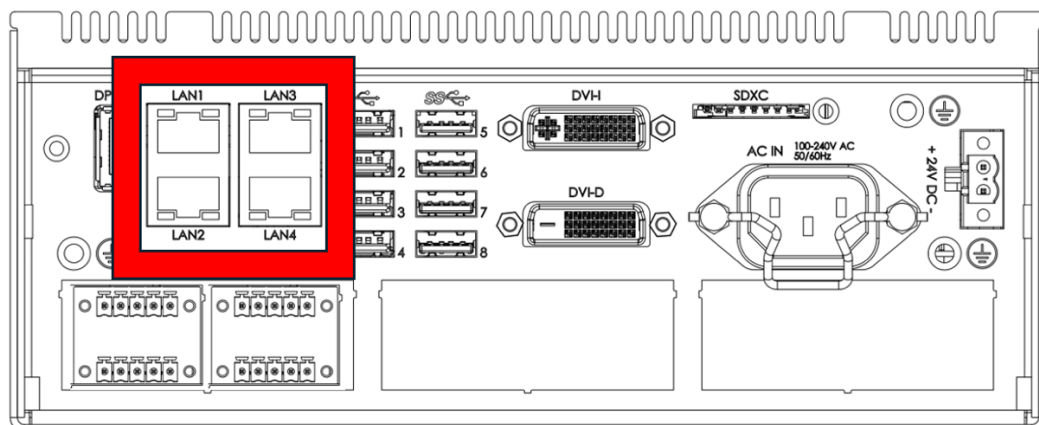

## COMPORTS

The COM ports are equipped with Phoenix 5-pin connectors and are intended for IEC 61162-1 (NMEA) connections.

- USB0 - GPS (RX+ RX-) (GGA or GLL and RMC, ZDA, VTG **(Requirement)**)
- USB1 - INS/ECDIS (RX+ RX-) (Nmea Out – Position, Gyro, Log, Wind, Sounder) **(Recommended)**
- USB2 - BAM / SPARE (RX+ RX- TX+ TX-) (Option read more section BAM)
- USB3 - VDR (TX+ TX-) (Option read more section VDR)

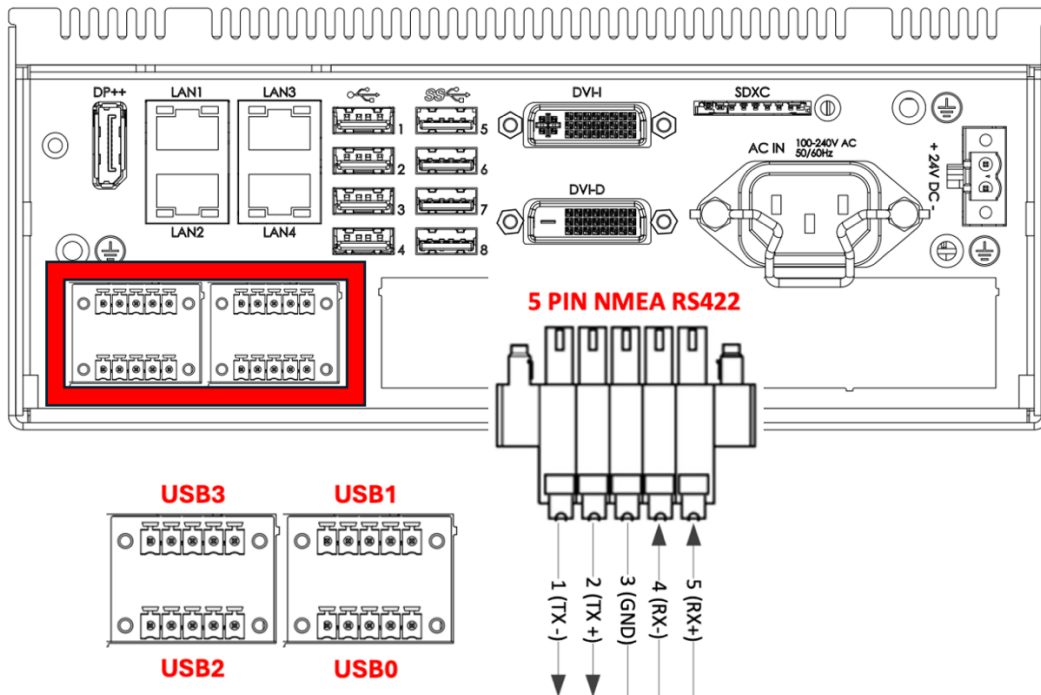

## VIDEO

TELSCOPE can be used as a workstation with directly connected Display **(Option)**

The monitor may be connected using any of the provided display connectors.

Ensure that the processor and monitor units are mounted and wired with common ground

Primary: DP++ (X1), Secondary: DVI (X2)

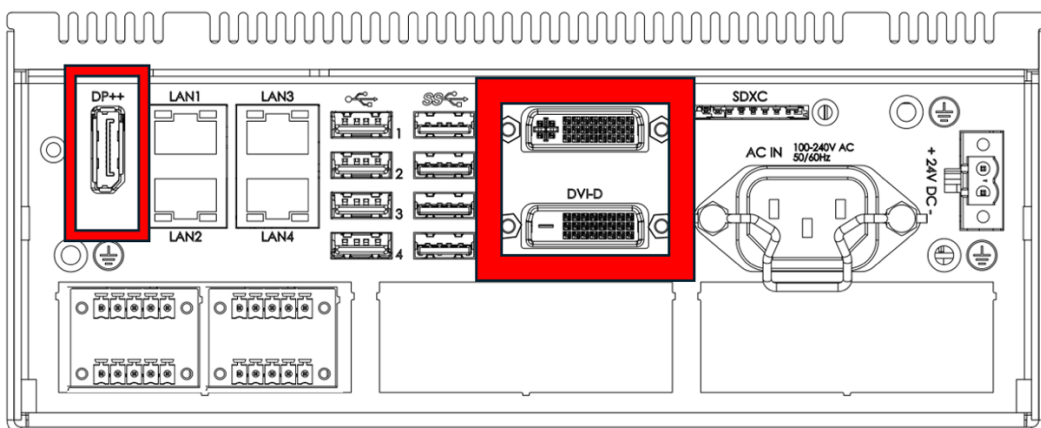

## USB

Use the provided bracket to block out USB connectors that are not in use

- USB Port (X8)

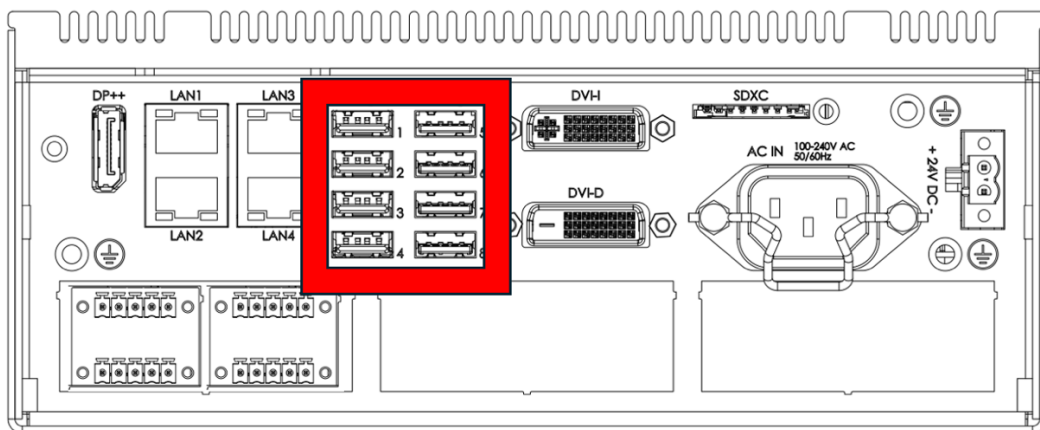

## BAM

TELSCOPE can be connected to the BAM system using the IEC 61162-1 (NMEA 0183) protocol. Serial port USB2 should be used for this connection. TELSCOPE exchanges messages as specified in ISO-21745 (Electronic record books for ships) and in accordance with the IEC 62923 (Bridge alert management) specification. The following alerts may be transmitted on this interface: Storage fault - Alert ID: 3063, Instance 1 Lost recording - Alert ID: 3009, Instance 1 UTC in fallback - Alert ID: 3113, Instance 1 Full 30 day log Alert ID: 3133, Instance 1 Security breach - Alert ID: 3136, Instance 1

Note that all alerts are category B, priority Caution. This implies that no acknowledgements on the BAM are required. Configuring TELSCOPE to connect to the BAM system Connect TELSCOPE to the BAM system via ttyUSB2. The BAM configuration can only be done by TELKO remote. To test the connection, monitor the connection on the BAM side. TELSCOPE will send ALC sentences every 30 seconds (Talker is RC, so the sentences will start with \$RCALC).

## INCLUDED IN BOX

Part:	Part Nr:	Manufacturer
3x Cable Retainer	HT RET STD-A1	Hatteland
2x Mounting Bracket	HT MBK STD-A1	Hatteland
1x Power Cable US Type	TP11/TC01-1,8M	Hatteland
1x Power Cable European Type	TP52/TC01-1,8M	Hatteland
4x 5-Pin Connectors (NMEA)	-	Hatteland
1x 2-Pin Connector (Power)	-	Hatteland
1x Server	HTB30GI-XXX-XXX-XXX	Hatteland
1x Documentation	-	Telko

## VDR

It is recommended to connect the Electronic Record Book to Ship's Voyage Data Recorded even if it not is a MUST requirement, but it is required by some Flag States.

It's the ship owner's decision if ERBL shall be recorded to Ship's VDR or not.

TELSCOPE can provide data via Serial Or Network

### VDR - IEC 61162-450 (Edition 2.0 2018-05)

LAN2 (enp4s0) - IEC 61162-450 (Option)

"Binary file transfer using UDP multicast", which uses 60021 to 60030

All settings can be change in TSW (Read more VDR - IEC 61162-450 Option)

#### Default Settings Output

IP: xxx.xxx.xxx.xxx      Subnet: xxx.xxx.xxx      Multicast: 600022  
SFI: RB0001      Destination SFI: VR0001      Device: 1      Chanel: 1

### VDR -IEC 61162-1 (NMEA 0183)

Default Serial port USB3 (D) pin 1,2 / 38400 Baud Rate is used on the TELSCOPE Server

All events are sent to VDR, if no events are made in TELSCOPE

the heartbeat will automatically start after 1 minute

`SRBXT,01,01,07,{"type":"HEARTBEAT"}*33`

For some manufacturers, in the VDR setup, the signal must be set to "Time Stamp Check" at the port to (0); otherwise, the VDR will trigger an alarm.

Examples of messages that refer to logbook entries like this are:

Strike through of entries. Master's signature. Remarks Verification of entries.

The format of the text encoded in the NMEA TXT sentences is json.

Example of logbook entry:

`SRBXT,15,01,01,{"creation_time":"2022-05-10-11-57-30"^2C"data":{"collected_d*7C`

`SRBXT,15,02,01,ata":{"STREAM:TELSCOPE.POS":{"collect_failure":false^2C"label*27`

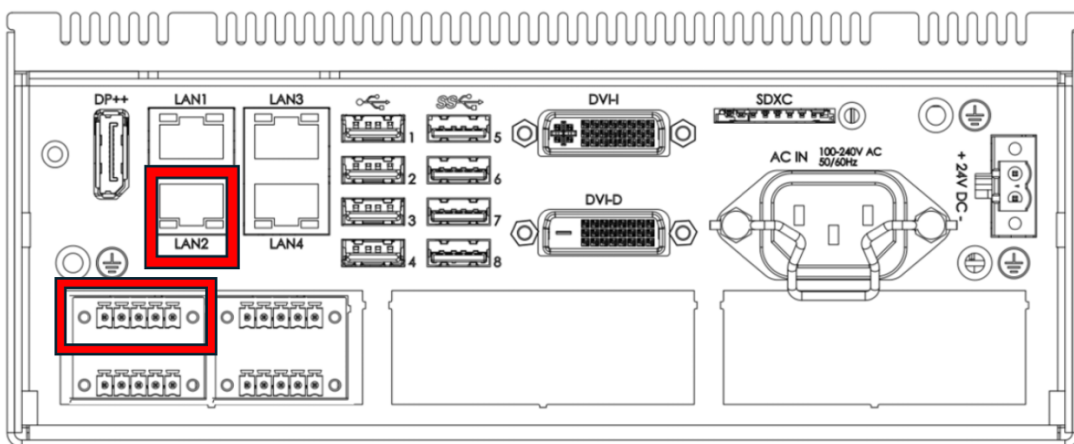



## SETUP TELSCOPE WITHOUT MONITOR (SERVICE PORT)

You can set up the TELSCOPE server without connecting a monitor by using a laptop connected via the "service port"(network interface enp2s0 – lower right port on the server).

### Step 1: Configure Your Laptop's Network

- You must assign your laptop an IP address within the same network (10.10.10.0/24). Follow these steps to set a static IP (instructions for Windows 10):

#### 1. Open Network Settings

- Click the network icon in the system tray (bottom right).
- Click "Network & Internet settings".

#### 2. Change Adapter Settings

- Click "Change adapter options".

#### 3. Open Ethernet Properties

- Right-click the Ethernet adapter that is connected to the TELSCOPE server.
- Click "Properties".

#### 4. Set IPv4 Address

- Select "Internet Protocol Version 4 (TCP/IPv4)" and click "Properties".
- Choose "Use the following IP address" and enter:
  - IP address: 10.10.10.20
  - Subnet mask: 255.255.255.0
  - Default gateway:10.10.10.1
- Click "OK" to save the changes.

### Step 2: Access the TELSCOPE Setup Interface

- Open any web browser on the laptop.
- Navigate to: <http://10.10.10.10>
- The TELSCOPE setup page should load and allow configuration.

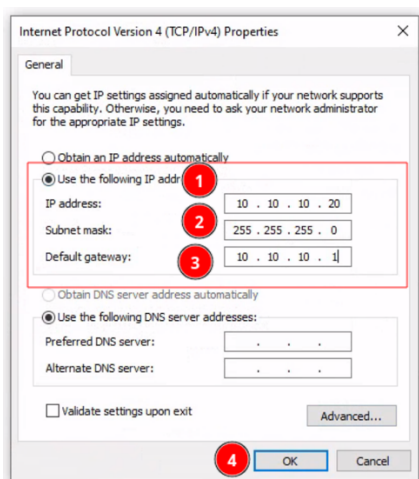



## TECDIS LINK TO TELSCOPE

TECDIS 4.8.3.6 s4 provides the following link to TELSCOPE

To activate the serial output to TELSCOPE:

Edit C:\Program Files (x86)\TECDIS\TELchart.ini.

Locate the setting "serial\_PTLK\_port" in the [Options] section, and set this to the serial port number connected to TelScope.

To add output:

Edit C:\Program Files (x86)\TECDIS\TELchart.ini.

Locate the setting "serial\_PTLK\_all" in the [Options] section, and set this to 1.

To adjust the baud rate used by TECDIS for this port:

Open TECDIS Setup.

Temporarily select the serial port for use on one of the sensors.

Select the desired baud rate.

Deselect the serial port from the sensor used in (2) above again.

Sentence \$PTLKC:

Value	Units	Fetcher field
ECDIS Palette (day/dusk/night)	-	ECDIS.PALETTE
Speed trough water	Knots	STW
Depth bellow keel	Meters	DPTH.KEEL
ECDIS license number	-	ECDIS.LIC
True Wind direction	-	WIND.TRUE.DIR
True Wind speed	Meter/Sec	WIND.TRUE.SPD
Rate of turn	Degrees/minute	ROT
ECDIS configured vesseldraught	Meters	DRAUGHT
Relative wind direction	Deg	WIND.REL.DIR
Relative wind speed	Meter/sec	WIND.REL.SPD
Bow transverse speed over ground	Knots (starboard +)	SOG.TRANS.BOW
Stern transverse speed over ground	Knots (starboard +)	SOG.TRANS.STERN
Longitudinal speed over ground	Knots (forward +)	SOG.FORW
Relative measurment of rudder angle	-(starboard +)	RUDDER
ECDIS number (1 or 2, or 3+ on multiple installs)	-	ECDIS.ID

When route monitoring is active, this is added:

Sentence \$PTLKW:

Value	Units	Fetcher field
Course to steer	Deg	WP.CTS
Next course to steer	Deg	WP.CTS2
Distance to wheelover line	NM	WP.DWOL
Time to go to next waypoint	Hours	WP.TTG
Cross track error	NM (starboard +)	WP.XTD
Route leg width to port	NM	WP.XPORT
Route leg width to starboard	NM	WP.XSTBD
Deviation from course to steer	Deg (clockwise +)	WP.DEV
Distance to wheelover line after next waypoint	NM	WP.DWOL2
Distance to go to end of route	NM	ROUTE.DTG
ID of next waypoint	String	WP.ID
ECDIS number (1 or 2, or 3+ on multiple installs)	-	ECDIS.ID

When “serial\_PTLK\_all” is set to =1 (activated) in TELChart.ini:

Sentence \$EIRMC:

Value	Units	Fetcher field
Position	“n.nnn, e.eee”	POS
Speed over ground	Knots	SOG
Course over ground	Deg	COG
Time	“YYYY-MM-DD HH:MM:SS.SSSS”	TIME
Position mode	Enum	POS.MODE

Sentence \$EIHDT:

Value	Units	Fetcher field
Heading	Deg	HDG

Sentence \$PTLKL:

Value	Units	Fetcher field
Type	-	-
LOP	-	-
Estimated Position	-	-



## NETWORK SETUP

Turn the system on and connect a LAN cable in the back of the system in the port named enp3s0  
For DHCP a static lease/reservation must be configured

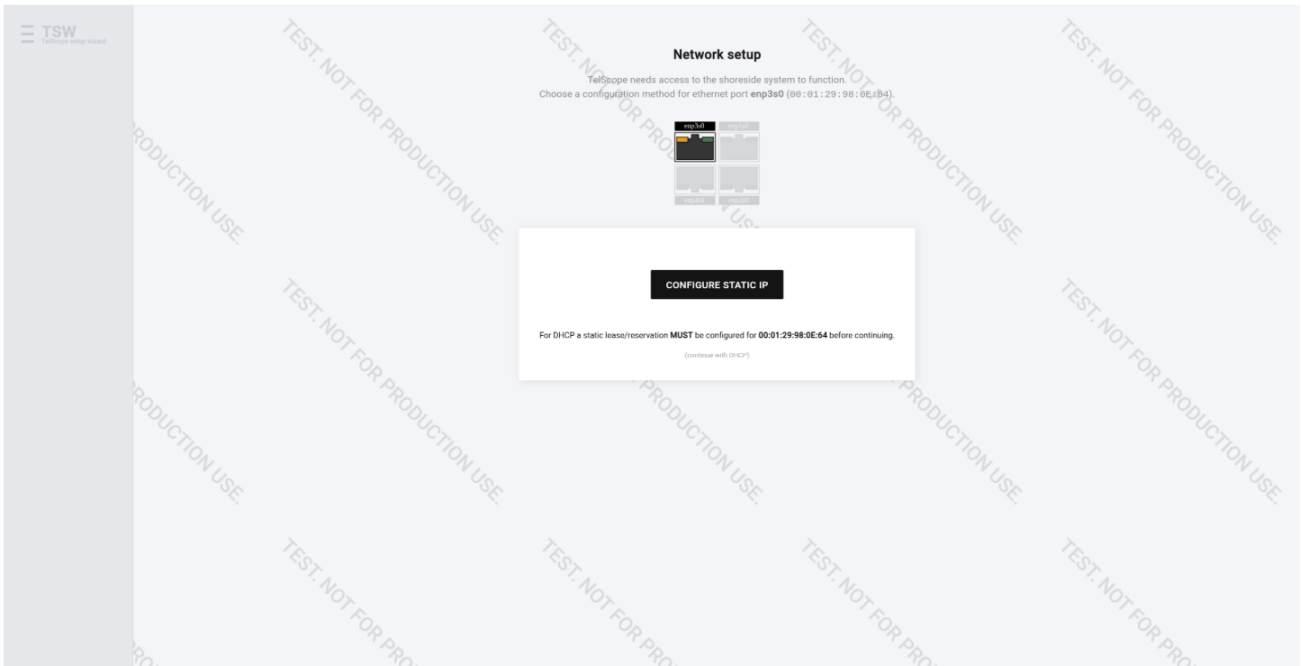

Setup (Static IP) button to access the next step where you will enter your static IP address.  
The IP address must be in the RFC1918 range 10.0.0.0/8, 172.16.0.0/12 or 192.168.0.0/16

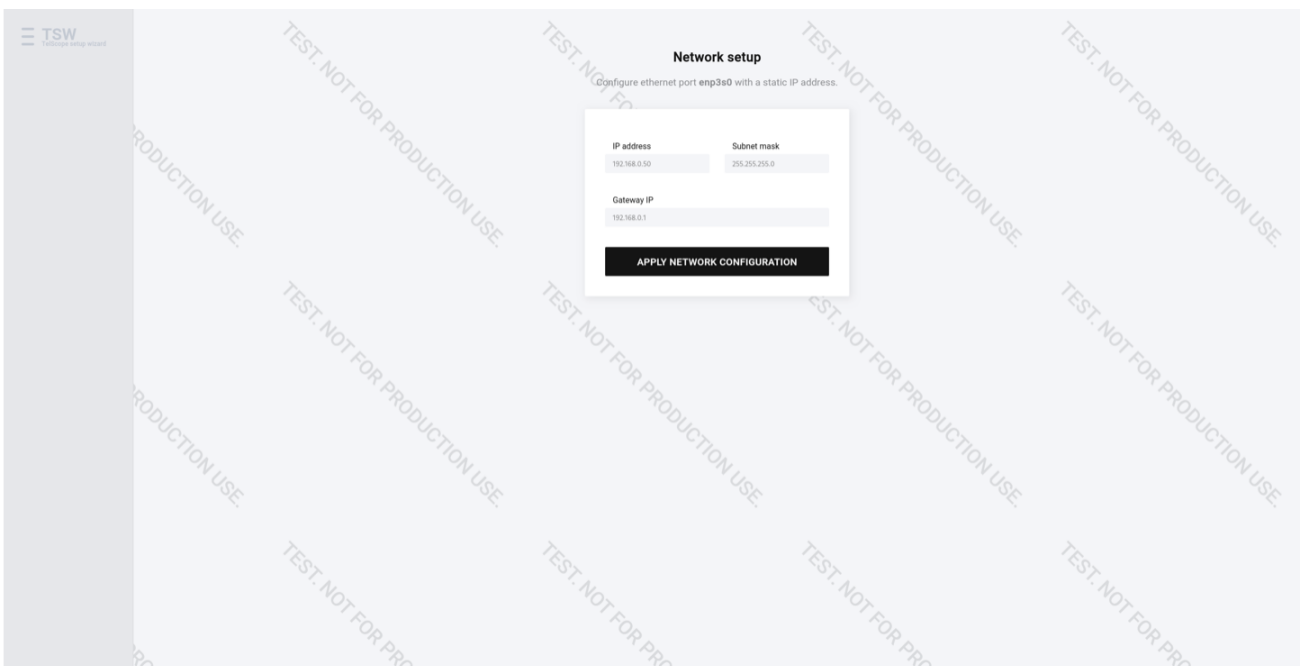

At this stage Network Setup Check page will be shown.  
This check will verify that the shoreside system can be reached.  
Press the Check Shoreside Connection button to continue  
If shoreside connection fails, double check that you have the LAN cable in the correct LAN port and check if your static IP is entered correctly. If the shoreside connection is complete, an overview page will be shown

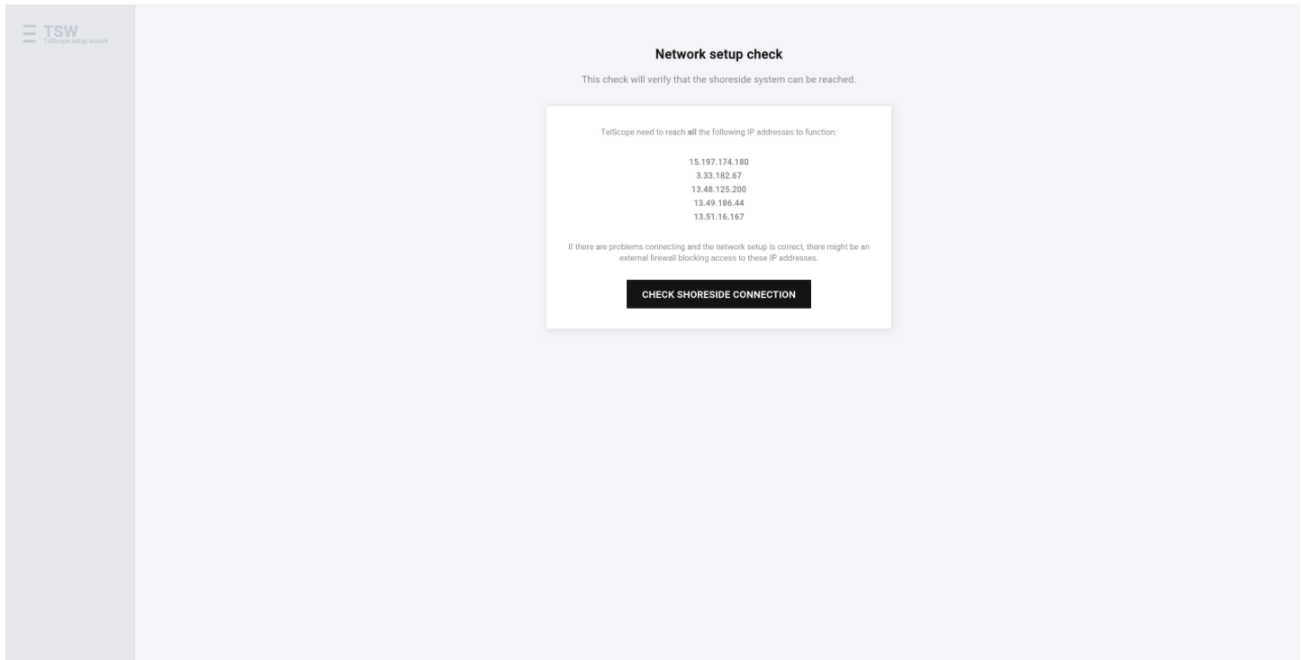

Assign Server to shore, In this step an IMO number or call sign is entered.  
This will permanently link the server to the given vessel, so make sure to enter the correct value

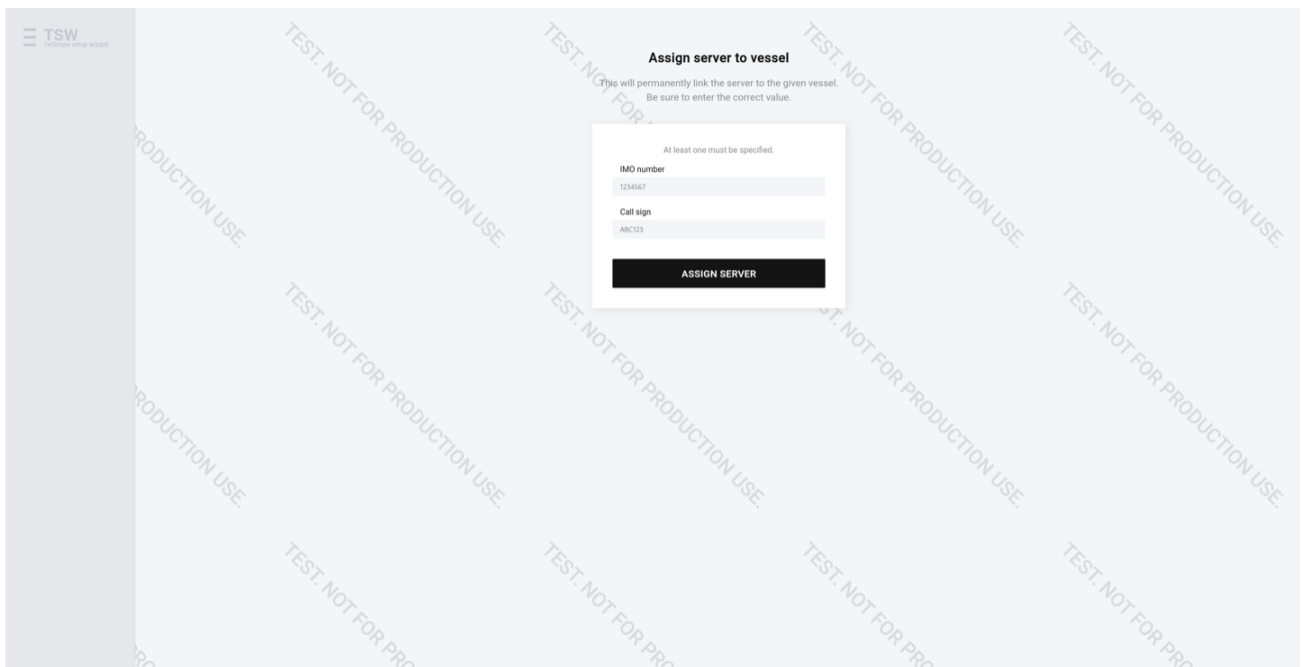

## OVERVIEW

At this stage, TELSCOPE has now received a connection to the shore and information about which TELSCOPE Version, Latest Handshake, IP Adress, Network Configuration, Target IP or URL

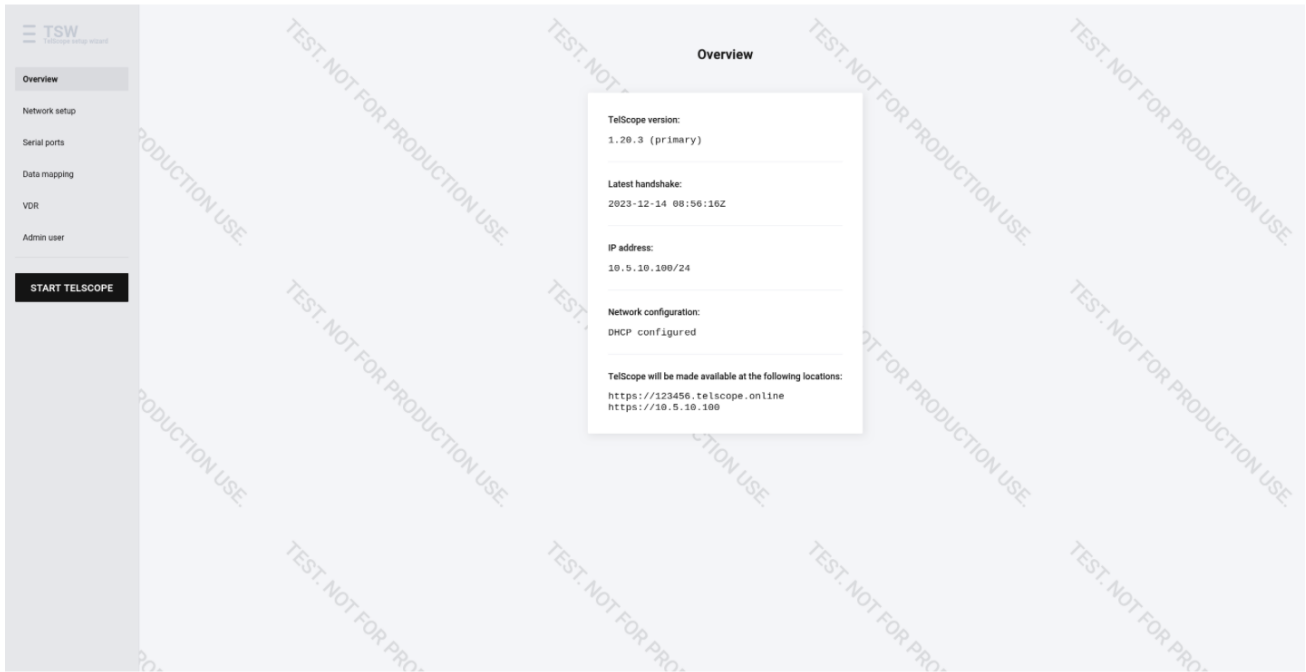

## DATA COLLECTION SERIAL

At least GPS (USB0) data should be configured for a working TELSCOPE installation. The Comports at the back of the TELSCOPE server are labeled with the same text as in this page. Data will be shown (if received) in the box below change to correct Baudrate

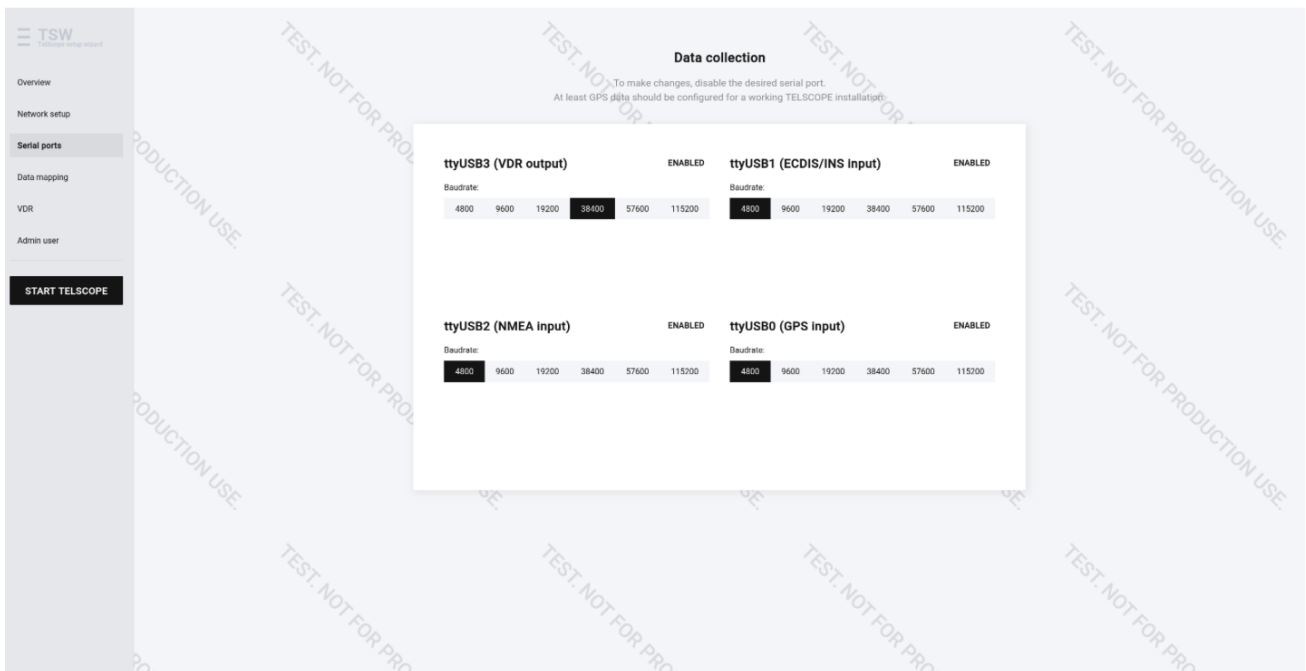

## DATA MAPPING

Please select the sources that should be used for the readings

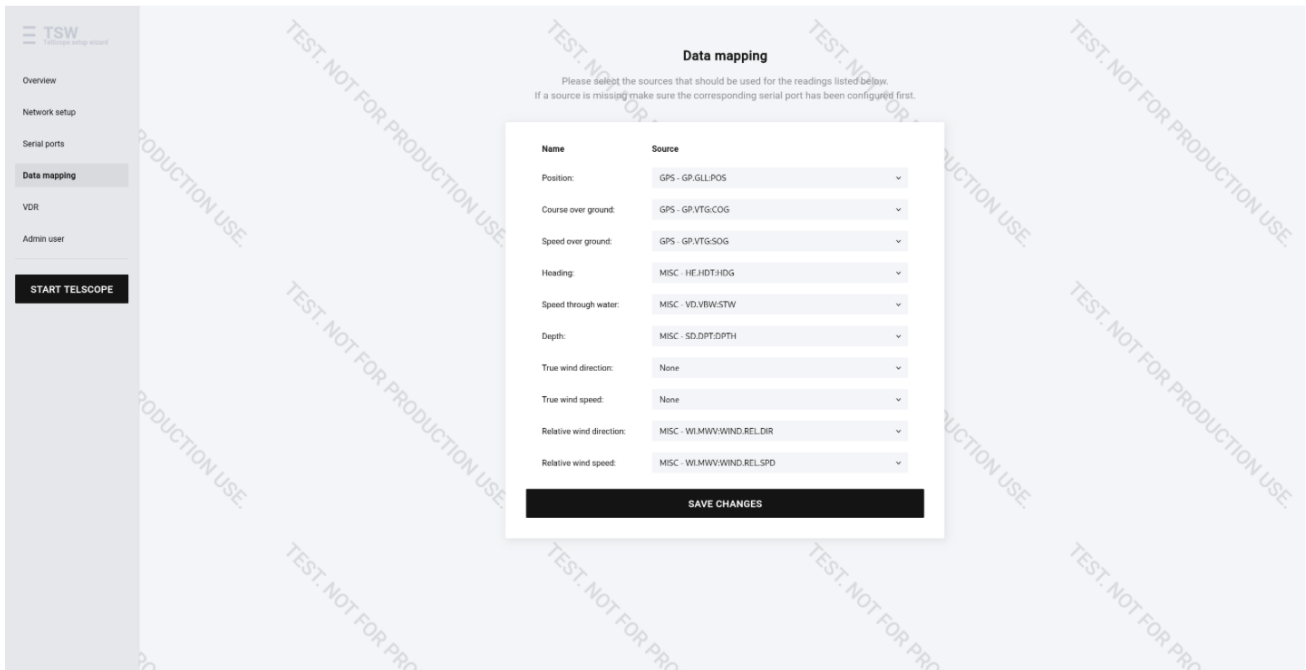

## VDR - IEC 61162-450 Edition 2.0 2018-05 (OPTION)

Configure TELSCOPE to send Logbooks Entries  
LAN2 (enp4s0) - IEC 61162-450 (Option)

"Binary file transfer using UDP multicast", which uses 60021 to 60030  
Fill in all relevant information (IP, Subnet, SFI, Destination SFI, Device, Chanel)

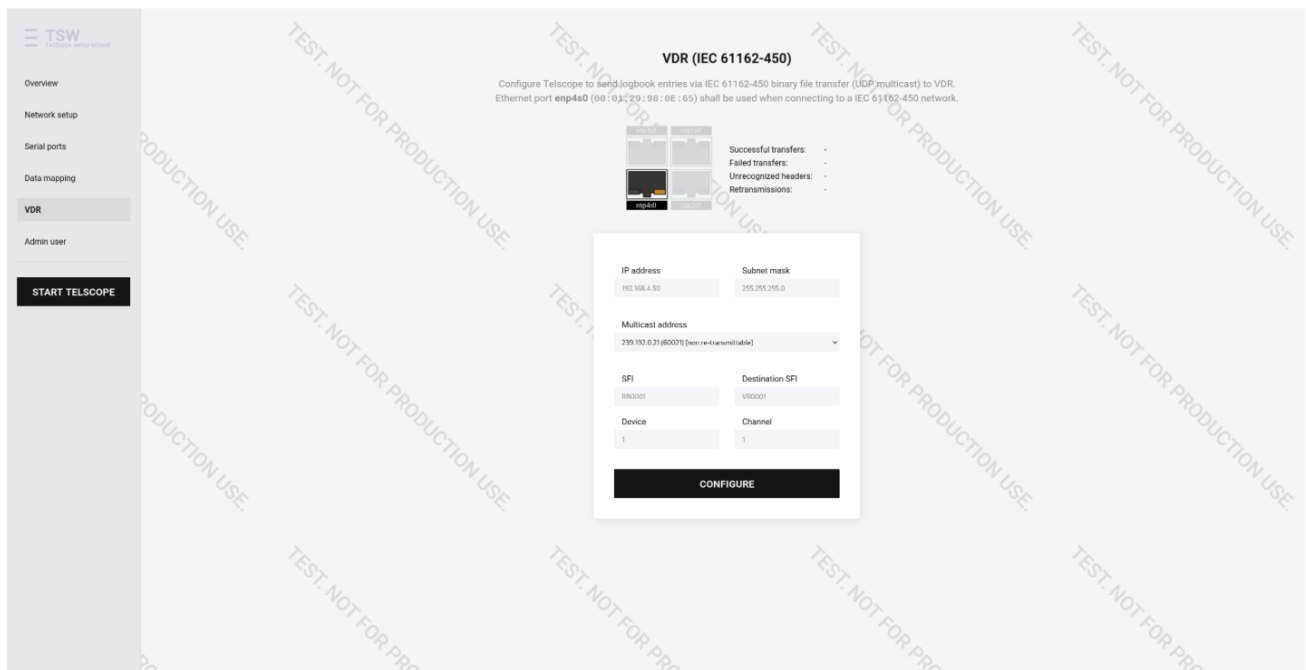

## ADMIN USER

Write the information on this page down, this is important as it will not be available after starting TELSCOPE. This user will be used for the initial TELSCOPE setup.

**Admin user**

Use this user for the initial TelScope setup.  
Remember to write this information down as it will not be available after starting TelScope.  
This information is used to sign into any TelScope server aboard this vessel.

Username:  
**administrator**

Password:  
**abcd1234**

Pincode:  
**123456**

## INSTALLATION REPORT

All required sections must be completed, please ensure that all relevant data is provided before selecting Submit. If the required information is missing or the checklist is not fully completed, TELSCOPE cannot be commissioned, and the vessel may not receive approval from Flag/Class. In such cases, a follow-up visit may be required.

**Installation report**

Please provide the requested information.  
An installation cannot be considered complete without submitting this report.

**Name of ship**  
Name of ship

**IMO number**  
1234567

**Call sign**  
ABC123

**Flag state**  
Flag state

**Gross tonnage**  
Gross tonnage

Installation according to Telescope installation manual  
 Ship's installation drawing and documentation provided to ship  
 Connection to ship network and internet following company guidelines  
 GPS/GNSS is connected  
 ECDIS/INS is connected (optional)  
 VDR is connected (optional)

**Remarks (optional)**  
Remarks

**Installer full name**  
Your full name

**Service company name**  
The company you work for

**Date**  
mm / dd / yyyy

**Place**  
Current location

Draw your signature below using mouse or touch Clear signature

.....

**SUBMIT**

## START / STOP

When all configuration is complete, press Start TELSCOPE. If this step is not performed, TELSCOPE cannot be used onboard.



In order to access the configuration tool, TELSCOPE must be stopped first (when service port are used)  
In cases where TELSCOPE has a display, keyboard, and mouse connected, the command Ctrl + Alt + Del can be used. In the dialog box, type setup.

